



# Ocean Sensor Systems, Inc.

## Wave Staff Synchronizers

### OSSI-012-012 & OSSI-012-012C

#### 6 Input Channels - for all Wave Staffs

### General Description

The OSSI-012-012 and OSSI-012-012C are designed to take synchronous samples from 2 to 6 Wave Staffs and combine the results to a single RS232 data stream at 38.4K baud. There is no need to pre-configure the Wave Staffs as they are automatically configured by the Synchronizers at power up time. Two or three Synchronizers may be linked together to simultaneously sample up to 12 to 18 Wave Staffs. The Synchronizers may be configured to free run or sample on command. They are available as a complete unit in a NEMA 4X box or they may be ordered as an OEM version, a PCB assembly.

### Features

- Automatically programs all Wave Staffs for Sync Mode
- Programmable Free Run Sample Rates, 2, 5, 10, 20, 30 Hz or on command.
- Programmable Time Tag each: Minutes, Hour or Day.
- Box Type NEMA 4X - Hinged Screw Cover Lid
- Cable Entries, Cord Grip, Protection Class: IP66
- Wide Input Voltage 5.8V to 34VDC
- Low Power Consumption 21 mA @ 12V and 16 mA @ 24V

### Wire Configuration

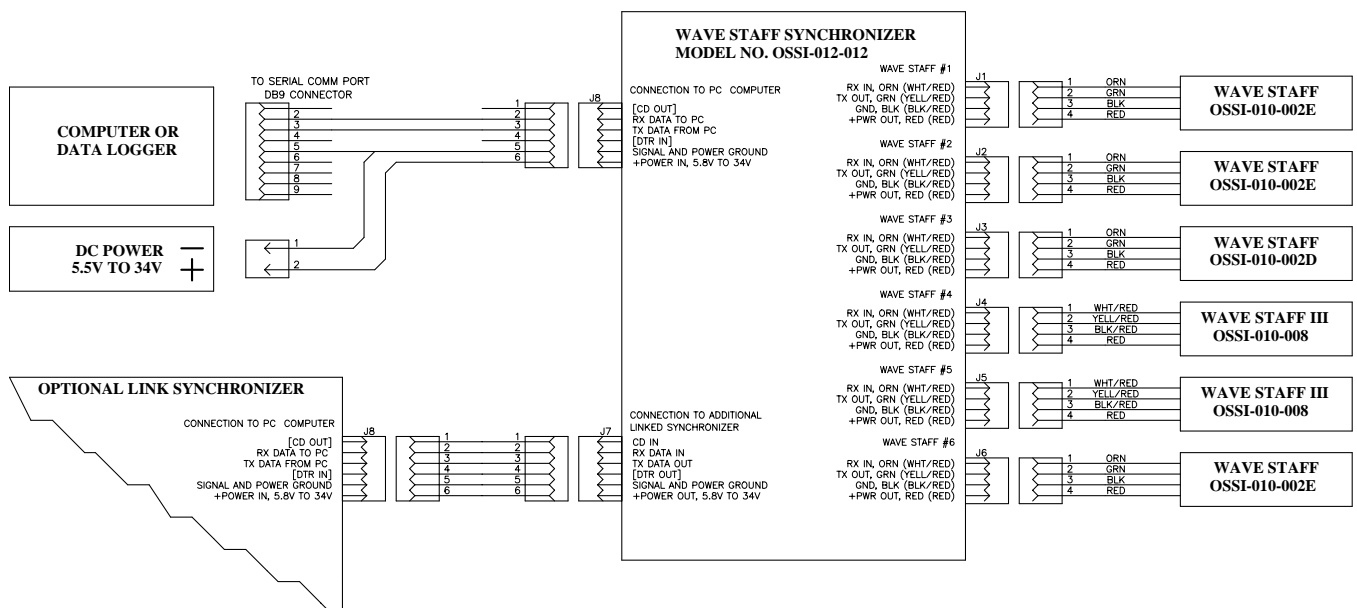

## Dimensions

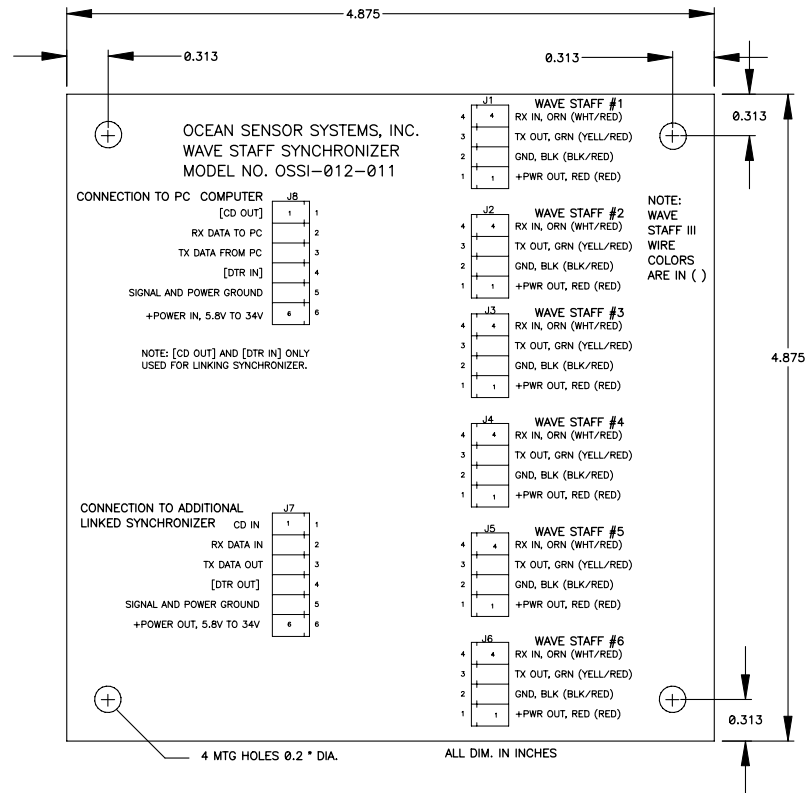

For Enclosure dimensions see Hammond Part Number PJ664H at <http://www.hammfg.com>

## Part Number

Part number	Product Name	Description 1	Description 2
OSSI-012-012	Wave Staff Synchronizer 6 Channel OEM	PC Board Only	
OSSI-012-012C	Wave Staff Synchronizer 6 Channel Case	Box Type NEMA 4X	Protection Class: IP66

## Electrical Characteristics

Parameter	Conditions	Min	Typ	Max	Units
Input Voltage Range		5.8		34	V
Input Current (Note 1)	12V DC input		21		mA
	24V DC input		16		mA
Output Voltage, connector J1 through J6	4 Amp fused Input Voltage	5.8		34	V
Operating Temperature		-10		65	Deg C

Note 1: Synchronizer power only. Add the power for each Wave Staff connected to obtain total power

## Data and Timing Characteristics

Parameter	Conditions	Min	Typ	Max	Units
Sample Frequency	Run Mode = Free	2		30	ms
	Run Mode = Command	0		30	Hz
Serial Data Baud	To Computer & Link J7 & J8		38.4		Kbaud
	To Wave Staffs J1 thru J6		9.6		Kbaud
Power up Delay	This time is used to automatically configure all wave staffs		6		Sec.

### Communications and Configuration:

The Wave Staff Synchronizer may be configured with a computer's, RS232 serial port. Use a Hyper Terminal with the following configuration: 38400 baud, 8 data bits, parity none, 1 stop bit, and no flow control.

### Stop Running Command:

To reconfigure the Wave Staff Synchronizer use the "st" command to enter the Configuration Routine. The st command equals "stop running sample routine and wait for configuration command."

**Warning :** wait for 6 seconds after power up before using this stop command otherwise the synchronizer will lock up and you will have to cycle the power again.

Below is an example of the result of typing the st keys.

```
st
*** Ocean Sensor Systems - Synchronizer ***
Serial Number: 00,00,00,0000
Code Rev: 1.00
Freerun Frequency: 10 Hz
Sample Mode: command
Time Tag: none

Select 'g' to return to Run Mode
Select 'm' to change the Run Mode
Select 'f' to change Sample Frequency
Select 'r' to read the Real Time Clock
Select 's' to set the Real Time Clock
Select 't' to set the Time Tag Frequency
```

### Commands in the Configuration routine:

The "m" equals "select either free run or command." Note: use the "g" key to exit the configure routine and also to initiate a sample when in the Command Mode.

Example:

```
m
Enter mode: freerun, command ('g' to sample)
```

The “f” equals “select the sample frequency in Hz. while in the Free Run Mode.”

Example:

*f*  
*Enter Sample Frequency: 2, 5, 10, 20 or 30*

The “r” equals “read the time and date of the Wave Staff Synchronizer’s real time clock.”

Example:

*r*  
*The Clock Date and Time is:*  
*MM-DD-YY HH:MM:SS*  
*10-04-07 18:49:03*

The “s” equals “enter a new time and date for the Wave Staff Synchronizer’s real time clock.”

Example:

*s*  
*Enter Clock Date and Time*  
*MM-DD-YY HH:MM:SS*

The “t” equals “Select the output Time Tag Interval.”

Example:

*t*  
*Enter Time Tag: none, min, hour, day*

The “enter key” equals “Display the Wave Staff Synchronizer’s configuration and the command set.”

The “g” equals “exit the Wave Staff Synchronizer’s Configure Routine.”

## **Wave Staff’s Configuration**

The Wave Staff Synchronizer automatically configures all connected Wave Staff ’s during power up. Simply connect the Wave Staffs to any one of the 6 connectors J1 thru J6. Only 4 wires need to be connected to the Power , Ground, Transmit and Receive terminals.

## **Serial output to a Computer or Data Logger**

The output to a computer or data logger (J7) is a RS232 serial data stream at 38.4 K baud. A four-conductor cable is needed to provide power and to access the serial data stream. Use connector J7’s Power , Ground, Transmit and Receive terminals.

The output data stream has a fixed length, comma separated format. It’s length is the same no matter the number of staffs connected. When multiple Synchronizers are linked together the first synchronizer’s data samples will display and then the next synchronizer and so forth in a continuous line until the end and then the next set of samples will begin on a new line. The commas separate channels 1 through 6 in ascending order for each synchronizer.

### Serial Output Examples:

Here is an example of a Synchronizer with Wave Staffs plugged into channel 2 and channel 5:

```
0000,0501,0000,0000,1062,0000,  
0000,0501,0000,0000,1062,0000,
```

Here is an example with a 2nd Synchronizer linked to the 1st Synchronizer and a Wave Staff plugged into the 2nd board's channel 3:

```
0000,0491,0000,0000,1062,0000,0000,0000,0757,0000,0000,0000,  
0000,0491,0000,0000,1062,0000,0000,0000,0757,0000,0000,0000,
```

Here is an example with a 3rd Synchronizer link to the 2nd Synchronizer and a Wave Staff plugged into the 5<sup>th</sup> and 6<sup>th</sup> channel:

```
0000,0491,0000,0000,1062,0000,0000,0000,0757,0000,0000,0000,0000,0000,0000,0345,2006,  
0000,0491,0000,0000,1062,0000,0000,0000,0757,0000,0000,0000, 0000,0000,0000,0000,0345,2006,
```

Here is an example of time tagged data:

```
0000,0501,0000,0000,1062,0000,  
0000,0501,0000,0000,1062,0000,
```

```
MM:07,DD:21,YY:07,HH:17,MM:10,SS:00  
0000,0501,0000,0000,1062,0000,  
0000,0501,0000,0000,1062,0000,
```

## Wave Staff Synchronizer Views

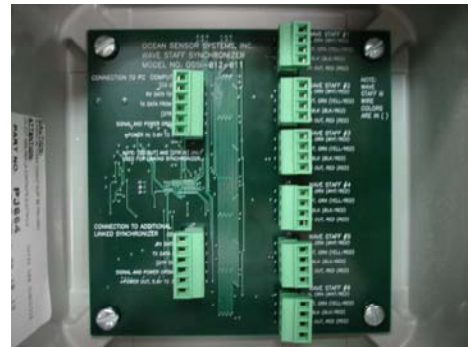
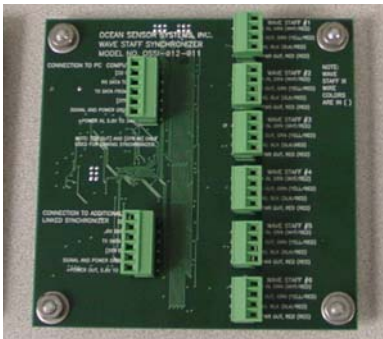

OSSI-012-012WS Synchronizer 6 Ch OEM

OSSI-012-012C Wave Staff Synchronizer 6 Ch in Case