



# Ocean Sensor Systems, Inc.

## Wave Staff, OSSI-010-002F, Water Level Sensor With 0-5V, RS232 & Alarm Outputs, 1 to 20 Meter Staff

### General Description

The OSSI-010-002F Wave Staff is a water level sensor that combines a rugged, sealed, waterproof package, low power microprocessor and a temperature stable, sensing circuit. The Wave Staff operates from 5.5V to 40VDC and has analog, RS232 serial data & 2 Alarms outputs. The serial data output string contains the water level & temperatures in ASCII or binary format. The Alarm Outputs are 350mA Open Drain type with 60V inductive load clamps. The Wave Staff can be programmed to free run or sample on demand. The Wave Staff is easily programmed via a PC serial port using our Wave Staff Interface Software or a Hyper Terminal program.

### FEATURES

- Programmable 0-5V or RS232 Data Out
- New Programmable Sample Rate Up to 110Hz
- Sample on Command for Simultaneous Sampling
- Programmable Air Temperature Serial Data Out
- Programmable High/Low Alarm Set Points
- 2 Alarm outputs, 350mA OD w/60V Clamps
- Rugged Sealed Waterproof Design
- Interchangeable Teflon Staff s up to 20 meters
- Wide Input Voltage 5.5V to 40VDC
- Low Power Consumption 18 mA
- Data Accuracy  $\pm 0.25\%$ , 20-80% of Full Scale
- Data Accuracy  $\pm 1.0\%$ , 0-100% of Full Scale
- Data Resolution 0.025%
- Data Linearity  $\pm 0.5\%$

### Wire Configuration and Dimensions

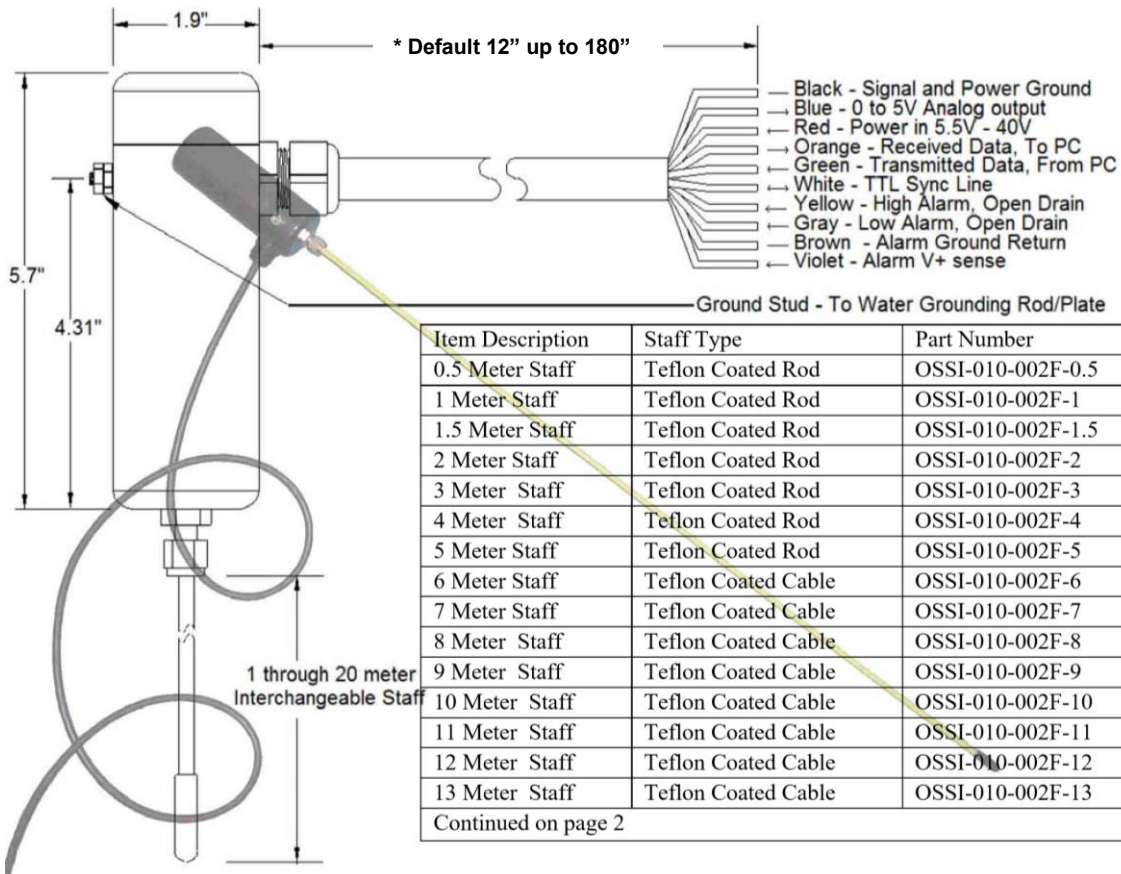

**Part Numbers cont.**

Item Description	Staff Type	Part Number
14 Meter Staff	Teflon Coated Cable	OSSI-010-002F-14
15 Meter Staff	Teflon Coated Cable	OSSI-010-002F-15
16 Meter Staff	Teflon Coated Cable	OSSI-010-002F-16
17 Meter Staff	Teflon Coated Cable	OSSI-010-002F-17
18 Meter Staff	Teflon Coated Cable	OSSI-010-002F-18
19 Meter Staff	Teflon Coated Cable	OSSI-010-002F-19
20 Meter Staff	Teflon Coated Cable	OSSI-010-002F-20
Standard operating temperature range is -10 °C to +65 °C add suffix T to Wave Staff part number for special -40 °C to +65 °C version		

**Electrical Characteristics**

Parameter	Conditions	Min.	Typ.	Max.	Units
Input Voltage		5.5		40	V
Input Current			18	23	mA
Data Accuracy	20-80% of Full Scale (3)			0.25	±%
Data Accuracy	0-100% of Full Scale			1.0	±%
Data Resolution	Percent of Full Scale			0.025	%
Data Linearity	Percent of Full Scale			0.5	± %
Analog Voltage Out	(Note 1)	0		5	V
Analog Voltage Out Noise, Peak	Percent of Full Scale (Note 2) 0-1MHz		5		mV
RS232 Data Out Noise, Peak	Percent of Full Scale		0.025		%
Alarm Battery Supply Voltage	Absolute maximum Recommended Operation	5.5		60V 25V	V
Alarm On Current	rDS On =1 Ω, Vbat=13V			350	mA
Alarm Shutdown V+ Sense Voltage	Alarms Open Drain Outputs are Disabled	30		38	V
Alarm Open Drain Voltage	Absolute Maximum Max. Operate			68 30	V

**Note 1: Accuracy is guaranteed from 8mV to 4.9V with => 5K ohms load.**

**Note 2: Serial Data deselected.**

**Note 3: The unit may need to be calibrated in-situ to meet the Data Accuracy**

## Data and Timing Characteristics

Parameter	Conditions	Min.	Typ.	Max.	Units
RS232 Sync Sample Time	From End of command to Start of Data Returned		6	7	mS
RS232 Free Run Sample Frequency		2		30	Hz
Analog Output Sync Sample Time	From rising edges of sync line to voltage updated	2		7	mS
Analog Output Sample Frequency		0		110	Hz
TTL Sync Plus Time		10			uS
Serial Data Baud Rate			9.6		Kbaud
Water Level Serial Data	0 to Full Scale 1 thru. 20 Meter Staff	0000		4095	counts
Temperature Resolution	Per count from 0°C		0.0625		°C
Temperature Accuracy	-10°C to 65°C -40°C to 65°C			0.5 2.0	± °C
Temperature Update Rate			1		Per Sec.

## Sample Rate Control:

TTL Run Mode Switch	Serial Output Switch	Com Port Run Mode Switch	Sample Rate Controlled by	Sample Rate	Serial Output	Analog Output On
Free	On	Free	Configured Sample Rate	2 to 30 Hz	Yes	Yes
		Sync	Serial Port Commands	0 to 33 Hz		
Sync	Off	Don't Care	Don't Care	100Hz	No	
	On		TTL Sync Line.	0 to 33Hz	Yes	
Sync	Off		TTL Sync Line.	0 to 110Hz	No	

## Communications and Configuration:

The Wave Staff may be configured with a PC's RS232 serial port. Use our convenient programming software or a Hyper Terminal with the following commands. The serial port settings on your computer are as follows: 9600 baud, 8 data bits, parity none, 1 stop bit, and no flow control.

Commands are two bytes and Acknowledgements are 4 bytes

Commands:

st = Stop running sample routine and wait for command instructions. w = Write configuration data to Wave Staff from PC. r = Read back configuration data to PC. i = Read back ID number to PC. g = Go run main sampling routine.

### Acknowledgements:

STOK = Acknowledge Stop running command and wait for command instruction.

WOK = Acknowledge Write configuration and wait to receive data from PC.

ROK = Acknowledge Transmit configuration and transmit configuration data to PC.

IOK = Acknowledge ID Command and transmit ID (serial) number to PC.

GOK = Acknowledge go command and go run main sample and store data routine.

BAD = Receive failure or check sum on configuration data error

DOW = Do, write configure Wave Staff. (Wave Staff has not been configured) DOK = Data Ok, Received configuration string with correct check sum

### Monitoring the sampled data:

The sampled data may be monitored via the RS232 serial port if the configuration control byte is set to enable the RS232 port:

Example with Air and Water Temperature enabled:

2345 +052 +048

2345 +052 +048

: :

2345 +052 +048

Example without Air or Water Temperature enabled:

2345

2345

:

2345

### Serial port Sync Mode Operation:

In Sync Mode the unit will transmit a dot when ready to receive a sample command. The Sample Commands may be either g or any two characters other than g.

1. The g command returns the sensor data first, a line end character second and a dot to indicate it's ready for the next sample command third.

The any character command initiates a sample with any key. Then a > is returned indicating the sampled data is ready. A second character must now be sent to receive the sampled data.

## Configuring the Wave Staff:

To Configure the Wave Staff a 44-comma separated 2 ASCII character string must be sent to the Wave Staff. Configuration String, Comma Delimited, Transmitted via RS232 serial port to Wave Staff

Offset	Length & Type	Name	Range and Description	
00h	3 ASCII bytes	Sensor Type	01, = Wave Staff	
03h	3 ASCII bytes	Staff length Counter	00, to FF, Hex value determined by Staff Length, See Table below "Staff Length Configuration values"	
06h	3 ASCII bytes	Staff length Pre scaler	XX, Hex value determined by Staff Length, See Table below "Staff Length Configuration values"	
09h	6 ASCII bytes	Gain Correction	00,00, to FF,FF, 16 bit unsigned Hex value, Gain correction value 1000 Hex = 0% 119A Hex = +10% 0E66 Hex = 10%	
0Fh	6 ASCII bytes	Zero Correction	80,00, to 7F,FF, 16bit Sign 2s comp. Hex value, Zero correction value 00,00, = 0 % 00,05, = +5 counts FF,FB = 5 counts, Correction is 1 for 1	
15h	3 ASCII bytes	Sample Frequency	02, or 05, or 0A, or 14, or 1E, Hex. Selects Sample Frequency 02, or 05, or 10, or 20, or 30 Hz	
18h	24 ASCII bytes	(reserved)	00, = Reserved space, 8 comma delimited 3 ASCII char.	
33h	3 ASCII bytes	Drain Enable	Bit 0 = All Alarms. Bit 1 = Alarm One and Bit 2 = Alarm Two 0 = disable and 1 = enable	
36h	3 ASCII bytes	Drain1OnH	Drain 1 on high hex byte	Trip value for Drain 1 high alarm 0 to 4095
39h	3 ASCII bytes	Drain1OnL	Drain 1 on low hex byte	
3Ch	3 ASCII bytes	Drain1OffH	Drain 1 off high hex byte	Reset Value for Drain 1 high alarm 0 to 4095
3Fh	3 ASCII bytes	Drain1OffL	Drain 1 off low hex byte	
42h	3 ASCII bytes	Drain2OnH	Drain 2 on high hex byte	Trip Value for Drain 2 Low alarm 0 to 4095
45h	3 ASCII bytes	Drain2OnL	Drain 2 on low hex byte	
48h	3 ASCII bytes	Drain2OffH	Drain 2 off high hex byte	Reset Value for Drain 2 Low 0 to 4095
4Bh	3 ASCII bytes	Drain2OffL	Drain 2 off low byte	
4Eh	51 ASCII Bytes	(reserved)	00, = Reserved space, 17 comma delimited 3 ASCII char.	
7Eh	3 ASCII bytes	Control Byte	See Control Byte Table below	
81h	3 ASCII bytes	Check Sum	00, to FF, Value is the sum of the Hex values in offset 00h to 81h (Note: Treat all Dec. values as Hex Values)	

Note 4: 00, = continuous

## Staff Length Configuration Values

Staff type	Staff Length Meters	Staff Length Counter Hex Value at offset address 03h	Staff Length Pre scaler Hex Value at offset address 06h
Rod	0.25	DF	03
Rod	0.5	DF	02
Rod	1.0	DF	01
Rod	1.5	94	01
Rod	2.0	DF	00
Rod	2.5	B2	00
Rod	3.0	94	00
Rod	3.5	FE	08
Rod	4.0	DF	08
Rod	4.5	C6	08
Rod	5.0	B2	08
cable	5.5	7C	08
cable	6.0	71	08
cable	6.5	69	08
cable	7.0	61	08
cable	7.5	5B	08
cable	8.0	55	08
cable	8.5	50	08
cable	9.0	4C	08
cable	9.5	48	08
cable	10.0	44	08
cable	10.5	41	08
cable	11.0	3E	08
cable	12.0	39	08
cable	13.0	34	08
cable	14.0	31	08
cable	15.0	2D	08
cable	16.0	2B	08
cable	17.0	28	08
cable	18.0	26	08
cable	19.0	24	08
cable	20.0	22	08

<b>Control Byte</b>	
Bit 7	0 = TTL Sync mode, Disabled 1 = TTL Sync mode, Enabled
Bit 6	1 = Sync mode: sensor waits for command via RS232
	0 = Free Run: Sensor samples at selected sample frequency
Bit 5	1 = Enable analog output 0 - 5V
	0 = Disable analog output
Bit 4	1 = Air Temp. enabled
	0 = Air Temp disabled
Bit 3	1 = Water Temp. enabled (External Sensor)
	0 = Water Temp disabled
Bit 2	0 = 9600 baud, default
Bit 1	1 = RS232 output enabled
	0 = RS232 output disabled
Bit 0	1 = BIN Data format
	0 = ASCII Data format.

**Sample 44 comma separated 2 ASCII character Configuring string:**

Example: 3 meter Staff, 20Hz sample rate, free run mode, air water temp enabled, RS232 enabled, ASCII data, High Low

Alarm outputs enabled.

01,3E,08,10,8C,FF,67,14,00,00,00,00,00,00,00,00,00,03,0B,B8,0B,54,03,E8,04,4C,00,00,00,00,00,00,  
00,00,00,00,00,00,00,00,00,00,00,00,00,00,3A,7F